

N - NUT F - PROGRESSIVE RING

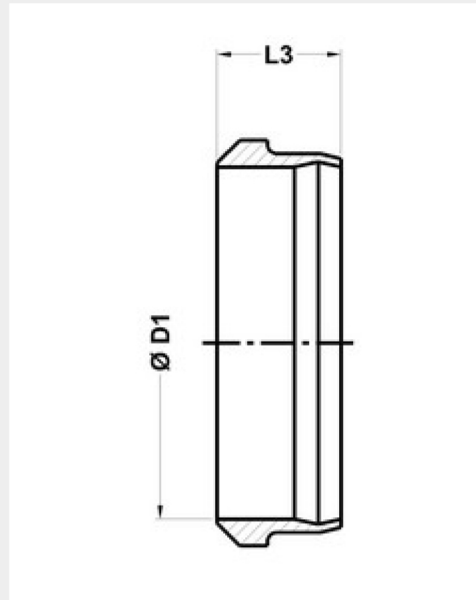

ORIENT ENGINEERING WORKS

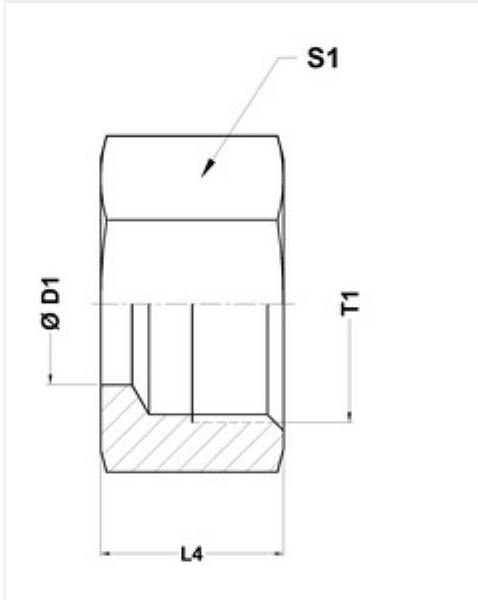

Part No.	Part No.	PN	D1	T1	L4	S1	L3
N 06-L	F 06-L	250	6	M12 X 1.5	14.5	14	9
N 08-L	F 08-L	250	8	M14 X 1.5	14.5	17	9
N 10-L	F 10-L	250	10	M16 X 1.5	16	19	9.5
N 12-L	F 12-L	250	12	M18 X 1.5	16	22	9.5
N 15-L	F 15-L	250	15	M22 X 1.5	17	27	10
N 18-L	F 18-L	160	18	M26 X 1.5	18	32	10
N 22-L	F 22-L	160	22	M30 X 2.0	20	36	10.5
N 28-L	F 28-L	100	28	M36 X 2.0	21	41	10.5
N 35-L	F 35-L	100	35	M45 X 2.0	24	50	13.5
N 42-L	F 42-L	100	42	M52 X 2.0	24	60	13.5
N 06-S	F 06-S	630	6	M14 X 1.5	16.5	17	9
N 08-S	F 08-S	630	8	M16 X 1.5	16.5	19	9
N 10-S	F 10-S	630	10	M18 X 1.5	17.5	22	9.5
N 12-S	F 12-S	630	12	M20 X 1.5	17.5	24	9.5
N 14-S	F 14-S	400	14	M22 X 1.5	20.5	27	10
N 16-S	F 16-S	400	16	M24 X 1.5	20.5	30	10.5