

WELDABLE TYPE FITTINGS

WC - WELD COUPLING

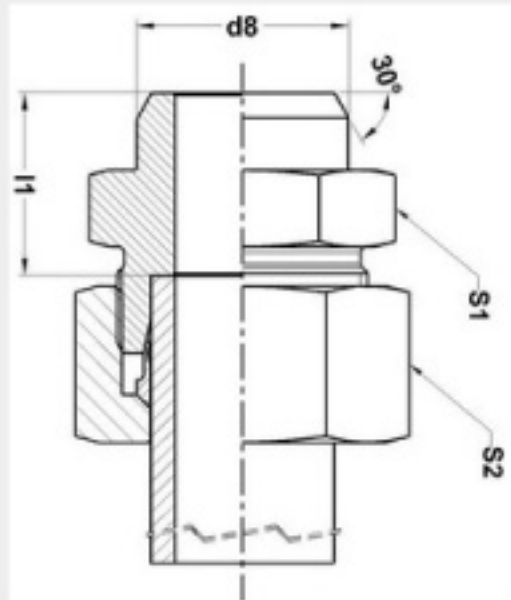

ORIENT ENGINEERING WORKS

Part No.	Series	Tube OD	S1	S2	l1	d8
WC 06-L	Light-250 Bar	6	12	14	14	10
WC 08-L	Light-250 Bar	8	14	17	16	12
WC 10-L	Light-250 Bar	10	17	19	18	14
WC 12-L	Light-250 Bar	12	19	22	18	16
WC 15-L	Light-250 Bar	15	22	27	22	19
WC 18-L	Light-160 Bar	18	27	32	23.5	22
WC 22-L	Light-160 Bar	22	32	36	28.5	27
WC 28-L	Light-100 Bar	28	41	41	30.5	32
WC 35-L	Light-100 Bar	35	46	50	32.5	40
WC 42-L	Light-100 Bar	42	55	60	35	46
WC 06-S	Heavy-630 Bar	6	14	17	19	11
WC 08-S	Heavy-630 Bar	8	17	19	21	13
WC 10-S	Heavy-630 Bar	10	19	22	22.5	15
WC 12-S	Heavy-630 Bar	12	22	24	24.5	17
WC 14-S	Heavy-400 Bar	14	24	27	27	19
WC 16-S	Heavy-400 Bar	16	27	30	26.5	21